

VSD-6-9-C
VSD-6-13-C

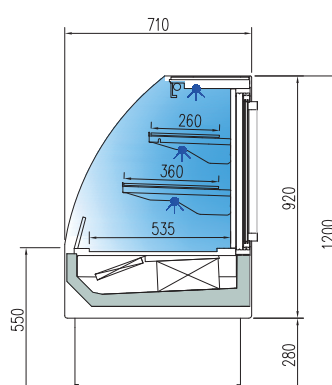

VSAD-6-9-C
VSAD-6-13-C

mod.	largo length (mm)	fondo depth (mm)	alto height (mm)	exposición display TDA(m ²)	puertas corredera sliding doors (uds)	refrigerante refrigerant	potencia frig. frig. power (W)	consumo consumption (W)	rango range
VSD-6-9	915	710	1200	0,66	2	R290*	1098	1309	+2°C+8°C
						R452A	1096	1376	+2°C+8°C
VSD-6-13	1285	710	1200	0,93	2	R290*	1098	1672	+2°C+8°C
						R452A	1315	1704	+2°C+8°C
VSAD-6-9	915	710	1200	0,66	2	R452A	1096	1379	+2°C+8°C
VSAD-6-13	1285	710	1200	0,93	2	R452A	1497	2003	+2°C+8°C

*opcional - optional

S-LINE

Características técnicas y constructivas sujetas a variación sin previo aviso

VSD vitrina cerrada, doble cristal frontal**VSAD** vitrina autoservicio

- Exterior fabricado en chapa de acero plastificada, parte inferior color gris RAL 7040
- Costados en cristal doble con serigrafía
- Interior en acero pintado epoxy
- **Cristal doble templado:** frontal, laterales y puertas
- Perfiliería en aluminio anodizado
- Estantes de cristal, con iluminación LED 6500 K, fijos en altura
- Opción LED 3000 K (luz cálida) o ROSA
- Aislamiento de poliuretano inyectado, densidad 40 Kg/m³, cero efectos ODP y GWP
- Evaporador ventilado
- Descarche automático con evaporación automática
- Condensación ventilada
- Control electrónico de temperatura
- Indicador de temperatura
- Clase climática 3 (25°C 60%)

We reserve the right to change specifications without prior notice

VSD double glazed front**VSAD** self-service

- External finish in plastic coated steel, base in grey color, RAL 7040
- Double glazed sides with serigraphy
- Epoxy painted internal finish
- Tempered double glazed: front, sides and doors
- Anodised aluminium profiles
- Glass shelves, with 6500 K LED lighting, height not adjustable
- Optional 3000 K LED (soft light) or PINK
- 40 Kg/m³ density polyurethane insulation, zero ODP and GWP
- Ventilated evaporator
- Auto defrost and automatic evaporation
- Ventilated condensation
- Electronic temperature controller
- External thermometer
- Climate class 3 (25°C 60%)

all photos must be considered as a reference - fotografías no contractuales



DE SERIE
STANDAR



VSD-6-13

Colores opcionales decoración frontal, incluidos en precio
Optional colors front decoration, free of charge

