

**IT**

Struttura a monoscocca in acciaio inox AISI 304; finitura esterna satinata scotch-brite; porte e cruscotto con angoli esterni arrotondati; spessore di isolamento 90mm per la scocca e 65mm per la porta, con schiuma poliuretana ad alta densità (40 kg/m<sup>3</sup>) senza HFC; piedini in acciaio inox regolabili h120/150mm; cella con angoli interni arrotondati per una perfetta pulizia ed igienicità; sbrinamento ed evaporazione dell'acqua di condensa a gas caldo; filtro condensatore amovibile di serie; griglie plastificate GN 2/1; fianchi interni stampati per 24 griglie GN 2/1 passo 55mm; flusso d'aria posteriore canalizzato; porte auto chiudenti con fermo a 100°; unità refrigerante a monoblocco brevettata e tropicalizzata (in classe climatica 5); serratura di serie; luce di serie; maniglia ergonomica a tutta altezza e doppia impugnatura; comando LCD a cristalli liquidi ad alta visibilità; alimentazione a 230V/50Hz monofase standard.

**EN**

Stainless steel AISI 304 monocoque structure; scotch-brite external satin finish; doors and front panel with rounded external edges; 90 mm high density HFC free polyurethane foam insulation (40kg/m<sup>3</sup>) for the body and 65mm thickness for the door; stainless steel adjustable feet h120/150; cell with rounded internal edges for a perfect cleaning and hygiene; hot gas defrosting and condensation water evaporation; removable condenser filter as standard; GN 2/1 plastic coated grids; pressed internal panels for 24 GN 2/1 grids; grid spacing 55 mm; rear ducted air flow; self-closing doors from 100°; patented and tropicalized monobloc refrigerating unit (climatic class 5); lock as standard; lights as standard; high visibility LCD liquid crystal control; full-height comfort double grip; standard power supply 230 V / 50Hz monophase.

**FR**

Structure à caisse unique en acier inox AISI 304 ; finition extérieure satinée Scotch-brite ; porte et panneau frontal avec angles arrondis ; épaisseur d'isolation par injection de mousse polyuréthane à haute densité (40 kg/m<sup>3</sup>) sans HFC de 90mm pour la caisse et de 65 mm pour la porte ; pieds réglables h120/150mm ; chambre froide avec angles internes arrondis pour un nettoyage et une hygiène parfaits ; dégivrage et évaporation de l'eau de condensation par gaz chaud ; filtre condensateur amovible de série ; grilles plastifiées GN 2/1 ; côtés internes moulés pour 24 grilles GN 2/1 pas 55 mm ; flux d'air arrière canalisé ; porte à fermeture automatique de 100° ; unité frigorifique avec monobloc breveté et tropicalisé (classe climatique 5) ; serrure de série ; éclairage de série ; contrôle LCD à cristaux liquides de haute visibilité ; poignée ergonomique à pleine hauteur et double manche ; alimentation standard 230 V / 50 Hz une seule phase.

**DE**

Monocoque-Ausführung aus Edelstahl AISI 304 mit satinierten Außenflächen (Scotch-Brite); 90 mm starke Rahmen-Isolierung und 65 mm starke Tür-Isolierung aus hochverdichtetem Polyrethanschaum (40kg/m<sup>3</sup>) ohne HFC; Stellfüße aus Edelstahl H 120/150; Kühlzelle mit abgerundeten Innenecken für eine einfache Reinigung und optimale Hygiene; automatische Kondenswasserverdunstung und Abtauung durch heißen Gas; Abnehmbarer Kondensatorfilter als Standardausstattung; GN 2/1 Kunststoff-Gitter; vorgeformte Interne Paneele für 24 Gitter GN 2/1 mit Abstand 55mm; hintere Leitungsluftstrom; selbstschließende Tür ab 100°; patentiertes und tropikalisiertes Monoblockkälteaggregat (Klimatische Klasse 5); serienmäßiges Schloss; Serienbeleuchtung; LCD Bedienfeld mit hochsichtbare Flüssigkristalle; ergonomischer Doppel-Handgriff in voller Höhe; Standard Spannung 230 V / 50 Hz einphasig.

**ES**





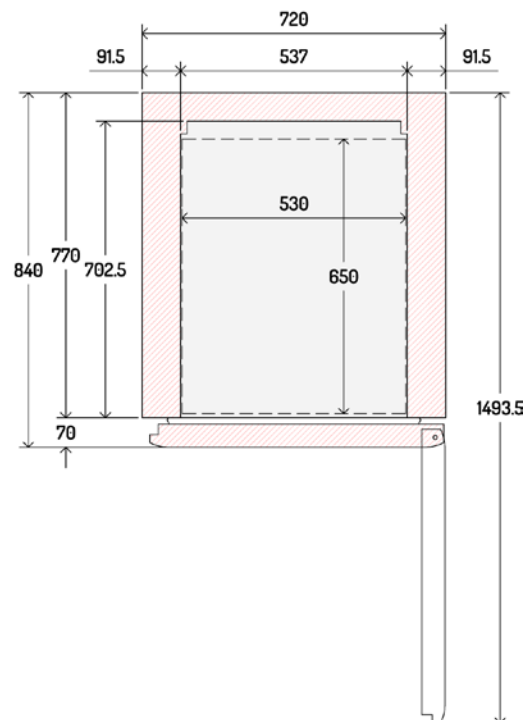
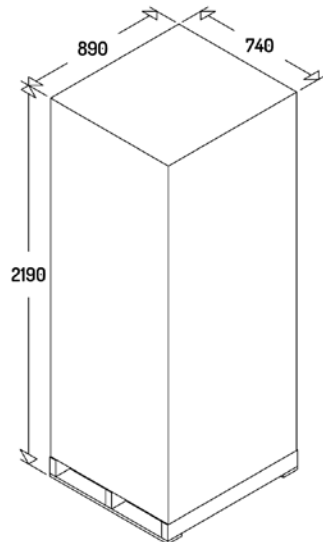
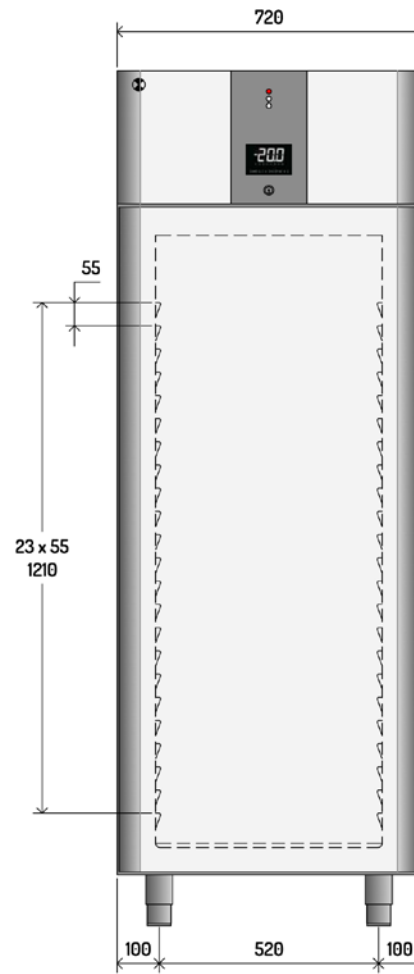
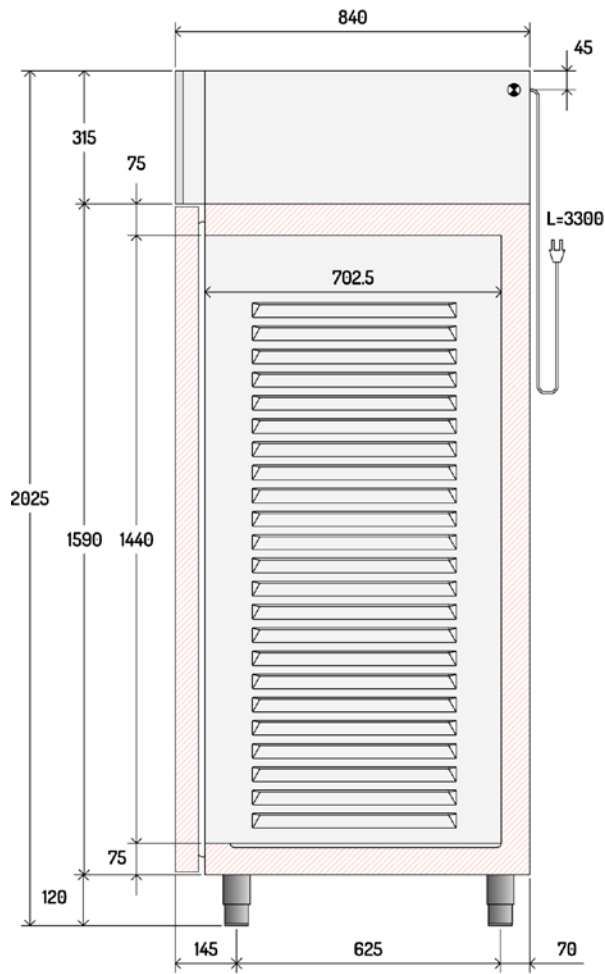

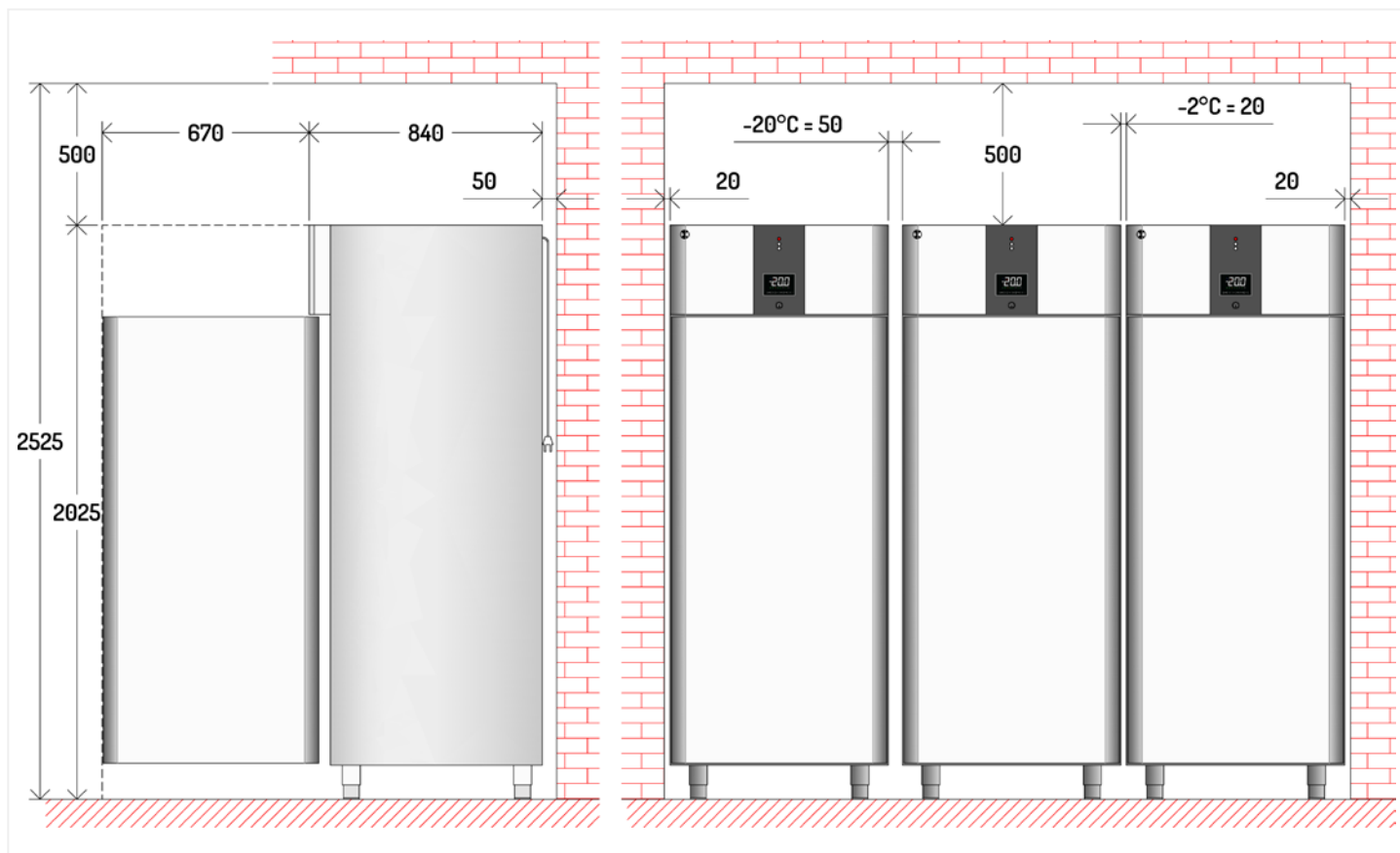









Estructura monocasco de acero inoxidable AISI 304; acabado exterior satinado scotch-brite; puerta y tablero con esquinas redondeadas; espesor de aislamiento 90 mm para el casco y 65 mm para la puerta con espuma de poliuretano de alta densidad (40 kg/m<sup>3</sup>) sin HFC; piés ajustable de acero inoxidable h120/150mm; cámara con equinas interiores redondeadas para un perfecta limpieza y higiene; deshielo y evaporación del agua de condensación a gas caliente; filtro condensador extraíble de serie; rejillas plastificadas GN 2/1, lado interior imprimido para 24 rejillas GN 2/1 "paso" 55mm; flujo de aria posterior canalizado; puertas con autocerrado con bloqueo a 100°; unidad refrigeradora monocasco patentada y "tropicalizada" (en clase climática 5); cerradura de serie; luz de serie; manija ergonómica por toda la altura y con doble empuñadura; mando LCD de cristal líquido de alta visibilidad; alimentación de 230V/50Hz monofásica estándar.







	<b>Ricambio Minimo Aria</b> Minimum Replacement Air	mc/h	280
	<b>Calore Emesso</b> Heat Output	watt	520
	<b>Versione Remota</b> Remote Version		
	<b>Linea di Aspirazione</b> Suction Line	mm	10
	<b>Linea Liquido</b> Liquid Line	mm	6
	<b>Potenza Sbrinamento Elettrico</b> Electric Defrost Power	watt	900

Modello - Model - Model - Gerätetyp		AEF7X2511
FST		
		
<input type="checkbox"/> <b>Descrizione</b> - Description - Description - Beschreibung		<b>700 FST</b>
 <b>Range</b>		<b>-22°C -15°C</b>
<input type="checkbox"/> <b>Funzionamento</b> - Operating Mode - Mode de fonctionnemen - Betriebsmodus S = Statico - Static - Statique - Stille Kühlung V = Ventilato - Ventilated - Ventile - Umluftkühlung		<b>V</b>
<input type="checkbox"/> <b>Capacità lorda</b> - Gross Capacity - Capacité brute - Bruttovolumen	l	540
<input checked="" type="checkbox"/> <b>Materiale Esterno</b> - External Material - Matériau Extérieur - Werkstoff Außen		<b>3 0 4</b>
 <b>Dimensioni esterne</b> - External Dimension - Dimensions externes - ußenabmessungen		
Lunghezza - Width -Largeur - Breite	mm	720
Profondità / con porte aperte - Depth / with open doors Profondeur avec portes ouverte - Tiefe/mit geöffneter Tü	mm	840/1495
Altezza - Height - Hauteur - Höhe	mm	2025
<input checked="" type="checkbox"/> <b>Materiale Interno</b> - Internal Material - Matériau Intérieur - Werkstoff Innen		<b>3 0 4</b>
 <b>Dimensioni interne</b> - Internal Dimension - Dimensions internes - Innenabmessungen		
Lunghezza - Width -Largeur - Breite	mm	537
Profondità - Depth - Profondeur - Tiefe	mm	702,5
Altezza - Height - Hauteur - Höhe	mm	1440
 <b>Porte</b> - Doors - Portes - Türen		1-DX, Full
<b>Dotazione Standard</b> - Standard Equipment - Equipement standard - Standardausstattung		Griglia plastificata - Plastic-Coated Grid -Grille Plastifée Kunststoff-Beschichtetes Gitter 3 (530x650)
<input type="checkbox"/> <b>Luce interna</b> - Internal light - Eclairage intérieure - Innerbeleuchtung		●
 <b>Serratura</b> - Lock - Serrure - Schloss		●
 <b>Sbrinamento</b> - Defrost - Dégivrages - Abtauen		
Type		Hot Gas
N° Defrost in 24 hrs.		INTELLI
Evaporazione acqua sbrinamento - Evaporation of defrost water Evaporation eau de dégivrage - Tauwasserverdunstung		Automatic by Hot Gas
 <b>Compressor</b>	<b>embraco</b>	
Model		NEU2168U
Potenza - Power - Puissance - Leistung	HP	3/4
T° Evaporation	°C	-30
Potenza frigorifera - Refrigerant Power - Puissance frigorifique - Kälteleistung	watt	600
 <b>Refrigerante</b> - Refrigerant type - Réfrigérant type - Kältemitteltyp	GWP	R290 / 3
<b>Quantità di refrigerante</b> - Refrigerant quantity - Quantité de réfrigérant - Kältemittelmenge	gr	120
 <b>Potenza assorbita</b> - Total Power - Puissance - Leistung	watt	530W 2,6A / 780W 3,7A
<b>Tensione alimentazione</b> - Supply Voltage - Tension d'alimentation - Anschlussspannung	V	230V~ 50Hz
 <b>Noise Level</b>	dbA	58
<input type="checkbox"/> <b>Peso Netto</b> - Net weight - Poids net - Netto Gewicht	kg	140
 <b>Versione Predisposta</b> - Remote version - Version sans groupe - Modelle ohne Aggregat Sbrinamento elettrico - Electrical defrosting - Dégivrage électrique - Elektrische Abtauung		<input type="checkbox"/>
 <b>Efficienza Energetica</b> - Energy Efficiency - Classe Énergie - Energieeffizienzklasse		B
 <b>Energia</b> - Energy - Énergie - Energie	kWh / annum	1289
<input checked="" type="checkbox"/> <b>Volume Netto</b> - Net Volume - Volume Net - Nettoinhalt	l	458
 <b>Classe Climatica</b> - Climate Class - Classe Climatique - Klima Classe		<b>5</b> 40°C-40%

●= Dotazione di serie - Standard equipment - Dotation standard - Serien Ausstattung =Optional