

**GAMME STANDARD**
**STANDARD RANGE**

PE18MC-TF

**PExMC-TF**

2 vitesses  
Cuve inox  
Tête fixe  
Outil inox  
Grille de protection inox relevable  
Pieds réglables

Minuterie  
Tableau de commande électromécanique  
Transmission par chaînes

**OPTIONS**

- Roulettes à frein (sauf sur PE60MC-TF)
- 1 vitesse : capacité 5, 8 ou 12 kg, nous consulter

**PExMC-TF**

2 speeds  
Stainless steel bowl  
Fixed head  
Stainless steel raising safety grid  
Stainless steel tool  
Adjustable feet

Timer  
Electromechanical control panel  
Chain transmission

**OPTIONS**

- Castors with brake (except for PE60MC-TF)
- 1 speed: capacity 5, 8 or 12 kg, please consult us

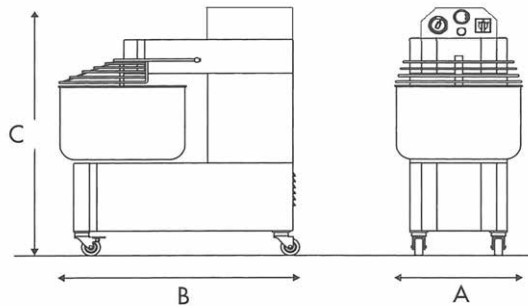

	PE18MC-TF	PE25MC-TF	PE38MC-TF	PE44MC-TF	PE60MC-TF
<b>Dimensions / Dimensions</b>					
A mm	410	430	480	550	585
B mm	715	770	820	878	1050
C mm	820	900	900	900	1210
C' mm (avec roulettes / with castors)	875	955	955	955	
C" mm (grille ouverte / grid opened)	1040	1150	1230	1240	1680
<b>Poids / Weight</b>					
Kg	70	95	110	120	226
<b>Capacités / Capacities</b>					
Cuve / Bowl (L)	20	33	40	50	75
Farine / Flour (kg)	12	17	25	30	40
Pâte / Dough (kg)	18*	25 *	38*	44*	60*
<b>Nombre de vitesses / Number of speeds</b>					
	2	2	2	2	2
<b>Puissance moteur / Motor power</b>					
1ère vitesse / 1st speed (kW)	0.6	1	1.5	1.5	2.6
2ème vitesse / 2nd speed (kW)	0.8	1.4	2.2	2.2	3.4
<b>Voltage / Voltage</b>					

TRI - 400V - 50/60Hz

\*avec hydratation à 60% et sous réserve du respect de l'utilisation mentionnée / With 60% hydration and subject to the respect of the mentioned using